

SACAGAWEA
DESIGNS

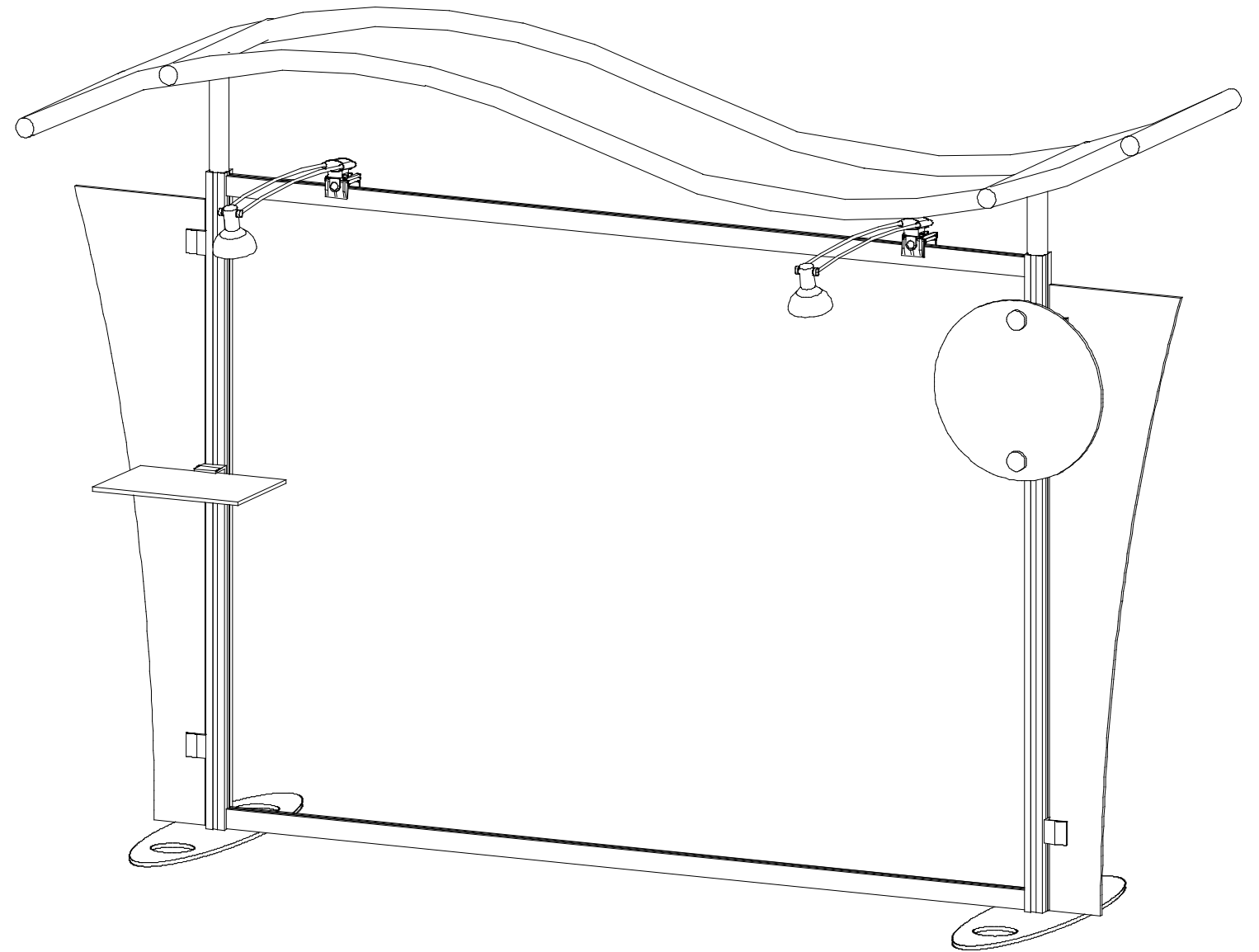
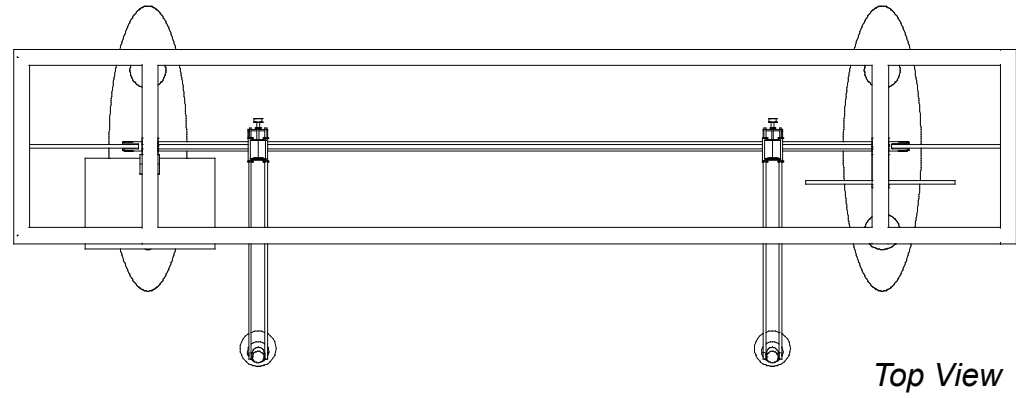

WHEN DISASSEMBLING ALUMINUM EXTRUSION, TIGHTEN ALL SETSCREWS AND LOCKS TO PREVENT LOSS DURING SHIPPING

SACAGAWEA DESIGNS

Using Your Set-up Instructions:

The Visionary Designs Set-up Instructions for Sacagawea displays are created specifically for your configuration. They are laid out sequentially, including an exploded view of the entire display and a logical series of detailed steps for assembly. We encourage you to study the instructions **before** attempting to assemble your exhibit.

THIS IS VERY IMPORTANT!

Each page reminds you to tighten the setscrews after disassembling your exhibit to prevent loss of the locks and setscrews (see below in red).

Cleaning & Packing Your Display:

- 1) Use care when cleaning aluminum extrusions or acrylic inserts. Use only non-abrasive cleaners.
- 2) When cleaning laminate inserts or counter tops, use mild cleansers and a soft material such as cotton.
- 3) Keep all display components away from extreme heat and long exposure to sunlight to avoid warping and fading.
- 4) Retain all packing materials. It will make re-packing much easier and will reduce the likelihood of shipping damage.

Hex Key Tool



Most visionary design exhibits can be assembled with the supplied Hex Key Tool. Occasionally, a flat head screwdriver may be required.

Typical Connection



Detail A: Most horizontal extrusion connections have a patented expandable lock. This lock inserts into the groove of an opposing extrusion. Tightening the lock with the Hex Key Tool expands the lock and creates a strong positive connection.

Typical Connection

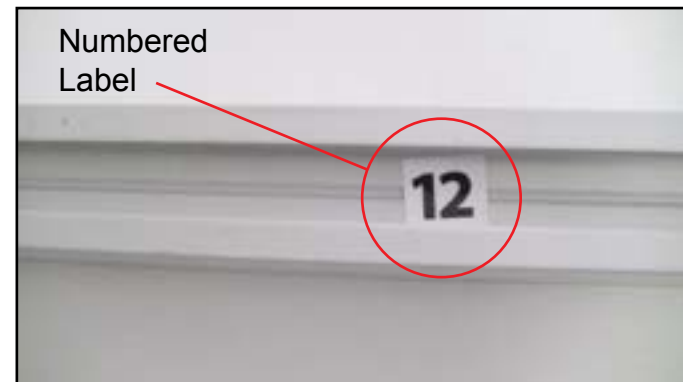

Detail B: Each extrusion contains a numbered label that corresponds to set-up instructions. The label is located within a groove of the extrusion (when possible). Visionary Design labels contain Black numbers unless otherwise specified.

Horizontal Connection



Detail C: A rectangular connection bar with plastic T Knobs is inserted between two horizontal extrusions joined end-to-end. Turn the knobs clockwise to tighten.

Do Not Overtighten.

Base Plate Connection



Detail D: Attach vertical extrusions to base plates with supplied bolts inserted through the hole in the plate. Be careful not to strip the thread.

Vertical Connection



Detail E: A square connection bar with plastic T Knobs is inserted between two vertical extrusions joined end-to-end. Turn the knobs clockwise to tighten.

Do Not Overtighten.

Corner Connection



Detail F: Plastic Star Knobs are used to tighten locks where horizontal extrusions connect with vertical extrusions. Turn the knobs clockwise to tighten. Turn counter-clockwise to loosen, but do not remove knob.

Do Not Overtighten.

WHEN DISASSEMBLING ALUMINUM EXTRUSION, TIGHTEN ALL SETSCREWS AND LOCKS TO PREVENT LOSS DURING SHIPPING

Item	Qty.	Description
1	2	Base Plate
2	1	42" h Square Vertical Extrusion w/ A10 Clamps Attached
3	1	42" h Square Vertical Extrusion w/ A10 Clamps Attached
4a/4b	1/1	27.5" w Horizontal Extrusion
5a/5b	1/1	27.5" w Horizontal Extrusion

Steps:

- 1) Attach vertical extrusions [2 and 3] to base plates [1].
- 2) Connect horizontal extrusions [4a,4b and 5a,5b] using connection bars.
- 3) Attach horizontal assemblies [4a/4b and 5a/5b] between vertical extrusions as shown.
- 4) Attach A10 clamp to front of vertical [2] for shelf.
- 5) Apply graphic to velcro on back of assembled backwall.

Graphic Attachment
Apply graphic to velcro on back of assembled backwall.

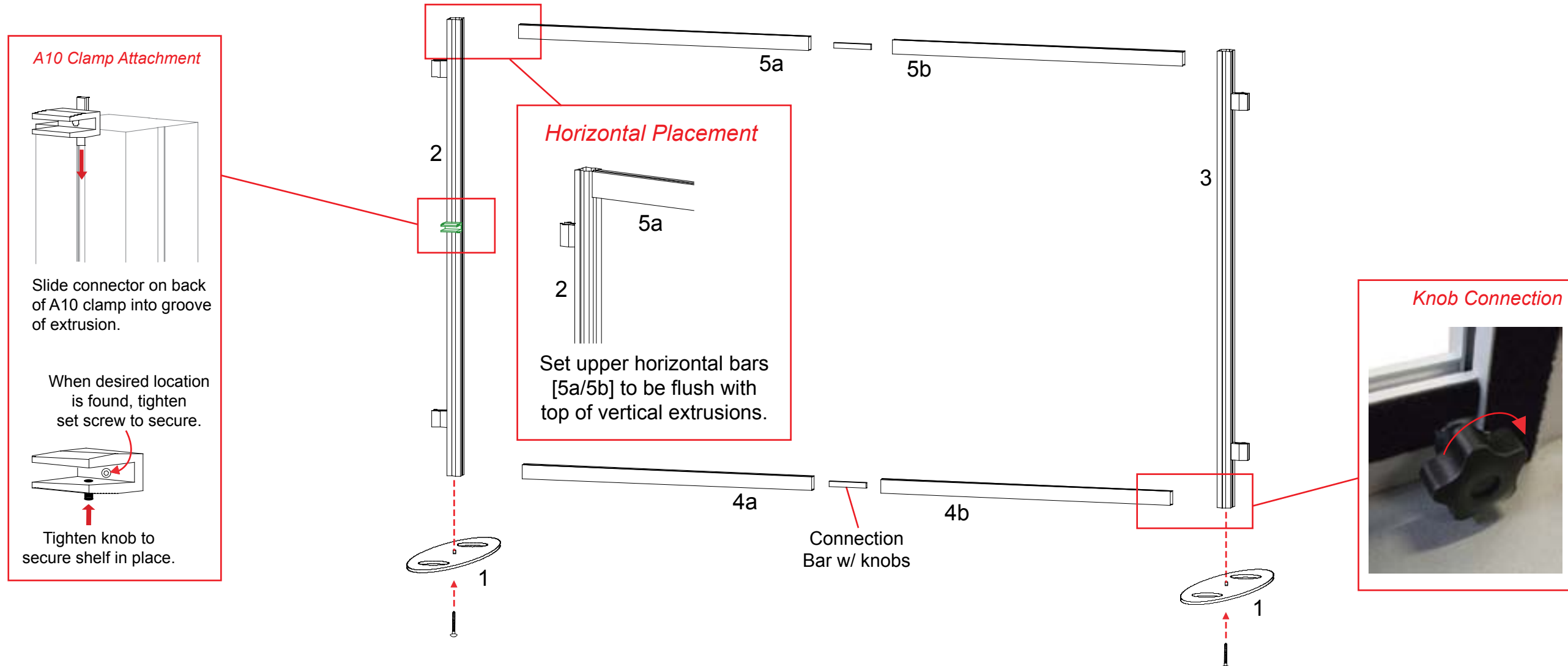

A10 Clamp Attachment

Slide connector on back of A10 clamp into groove of extrusion.

When desired location is found, tighten set screw to secure.

Tighten knob to secure shelf in place.

Horizontal Placement

Set upper horizontal bars [5a/5b] to be flush with top of vertical extrusions.

Knob Connection

WHEN DISASSEMBLING ALUMINUM EXTRUSION, TIGHTEN ALL SETSCREWS AND LOCKS TO PREVENT LOSS DURING SHIPPING



Using Your Setup Instructions

The Aero Overhead Sign Setup Instructions are created specifically for your configuration. They include an exploded view of the frame which is sequentially numbered. We encourage you to study the instructions before attempting to assemble your exhibit.

Connections are kept very simple: no tools. Everything assembles with push-button connectors and pre-connected horizontal sections.

Cleaning and Packing Your Display

- 1) Use care when cleaning aluminum extrusion or acrylic inserts. Use only non-abrasive cleaners.
- 2) Retain all packing material. It will make re-packing much easier and will reduce the likelihood of shipping damage.

Steps:
Use push-button connection to assemble canopy pieces together as shown.

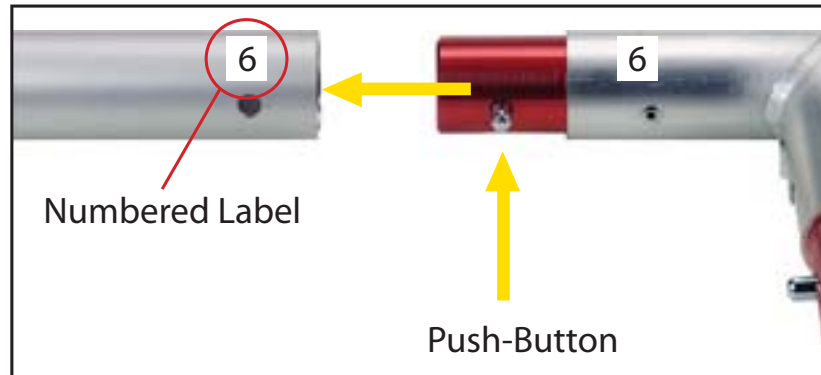

Connections are made by holding the button down and sliding the red tube into opposing tube until the connection is made. To disassemble push button and pull or twist extrusions apart.

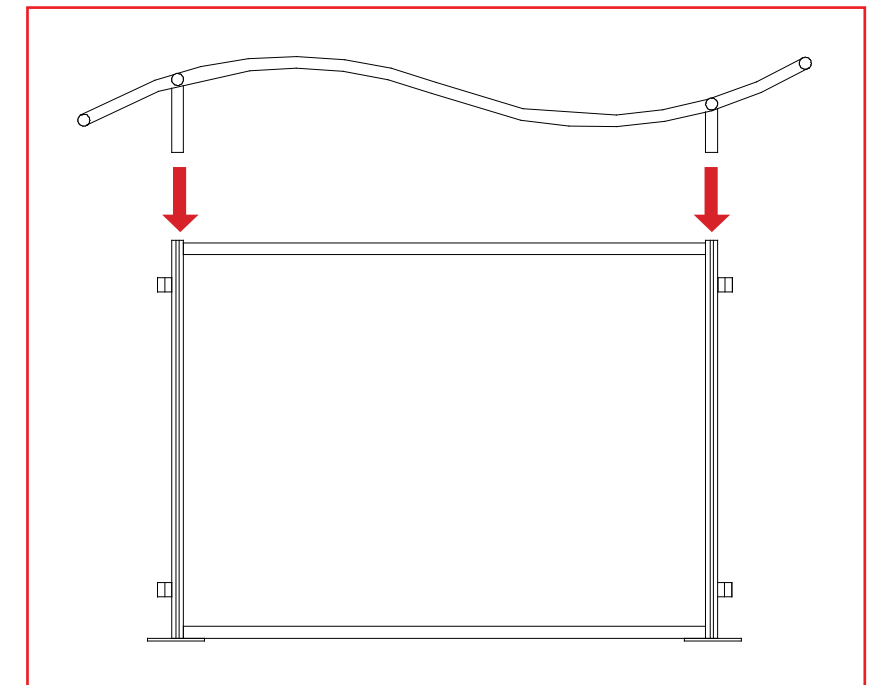
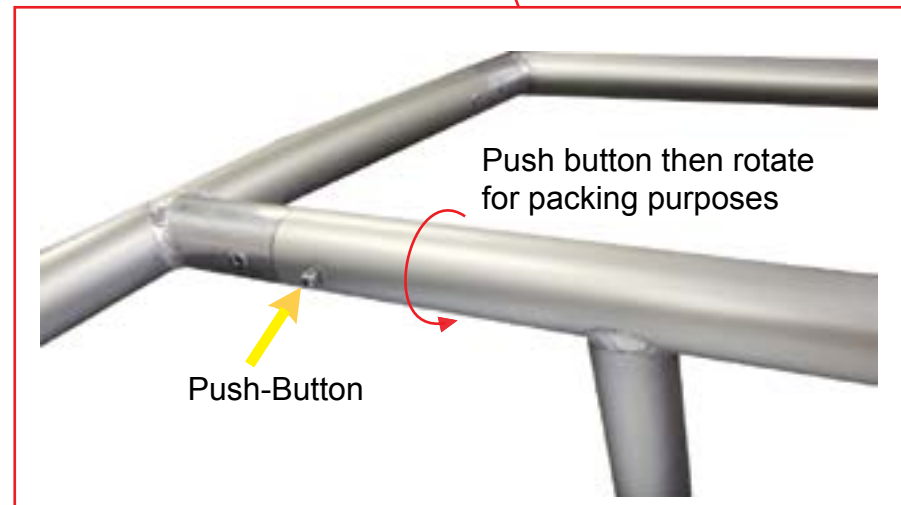
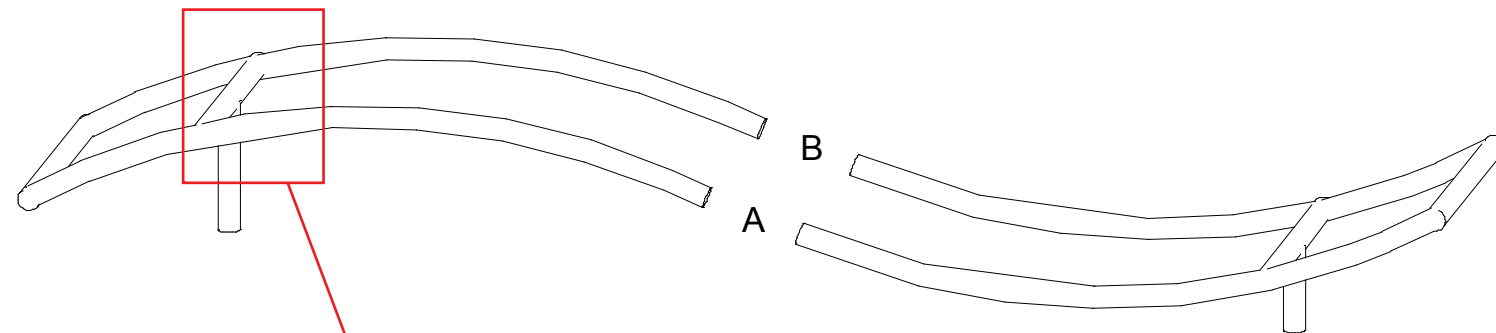
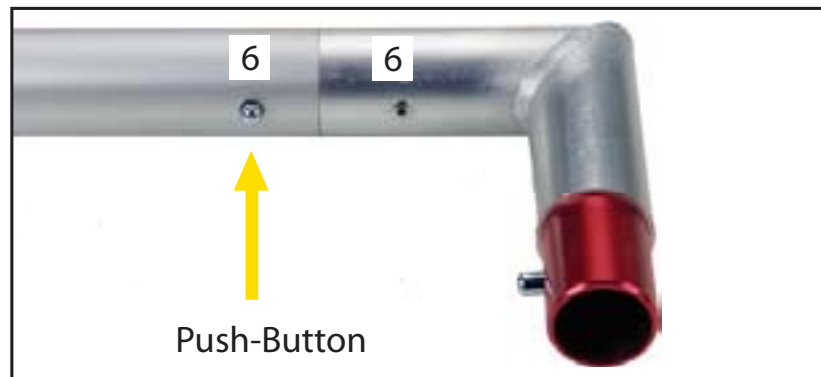

WHEN DISASSEMBLING ALUMINUM EXTRUSION, TIGHTEN ALL SETSCREWS AND LOCKS TO PREVENT LOSS DURING SHIPPING

Steps:

- 1) Attach canopy to top of verticals.
- 2) Attach wing panels and plex shelf to A10 clamps.
- 3) Attach round sign to vertical where indicated using stand-offs.

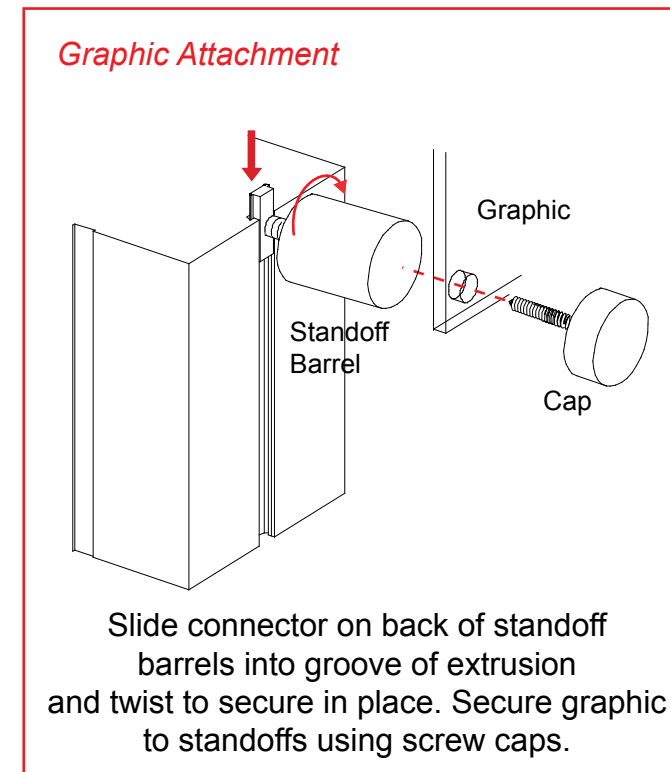
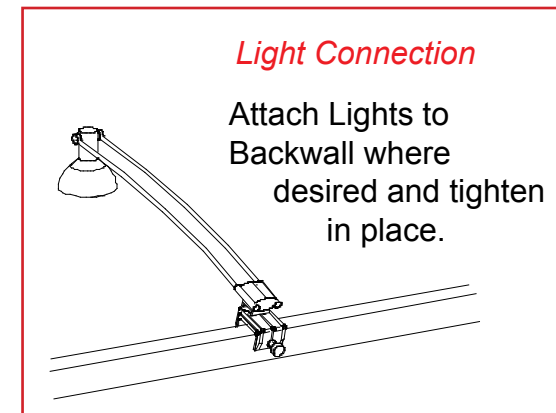
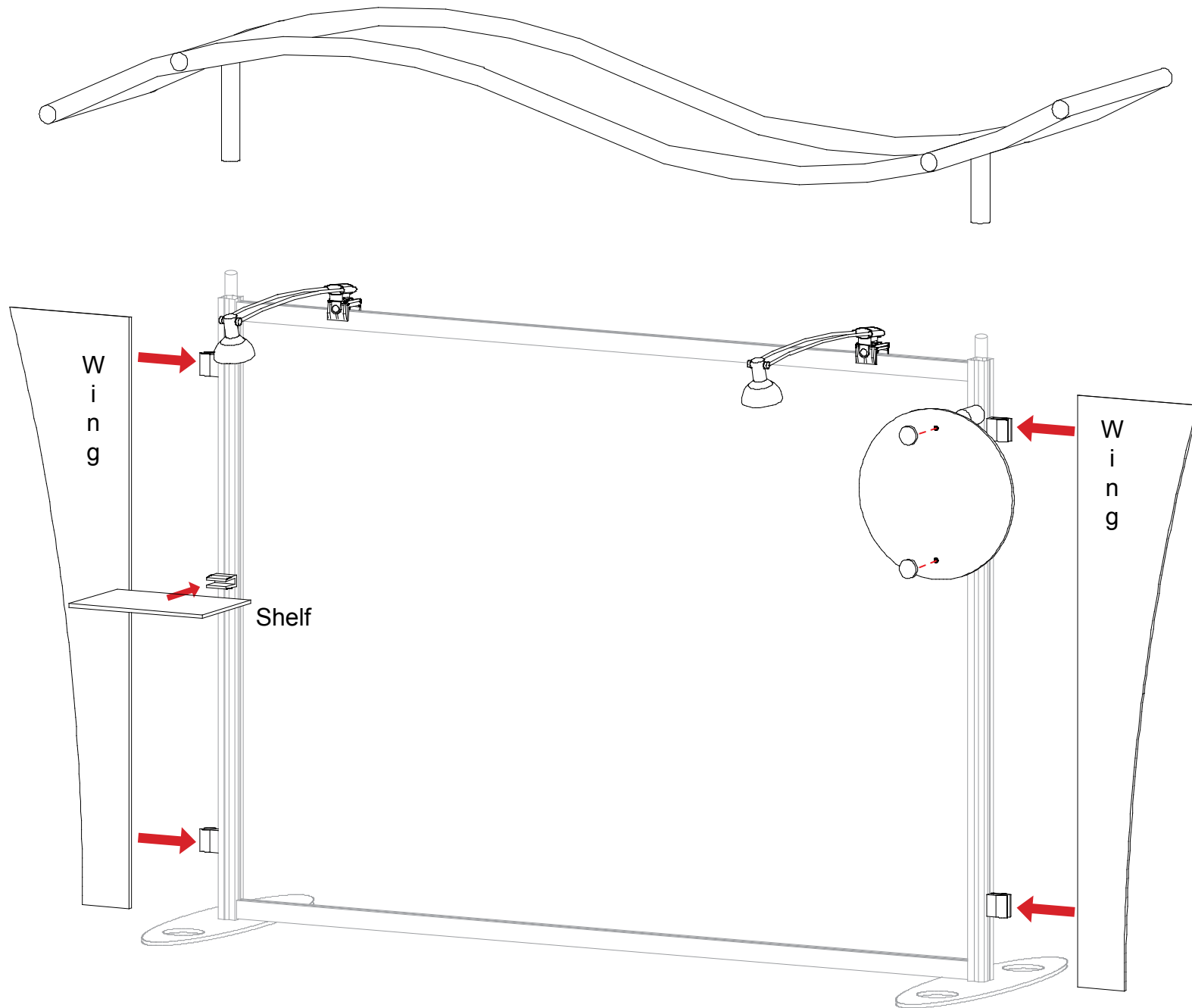

WHEN DISASSEMBLING ALUMINUM EXTRUSION, TIGHTEN ALL SETSCREWS AND LOCKS TO PREVENT LOSS DURING SHIPPING

Top View

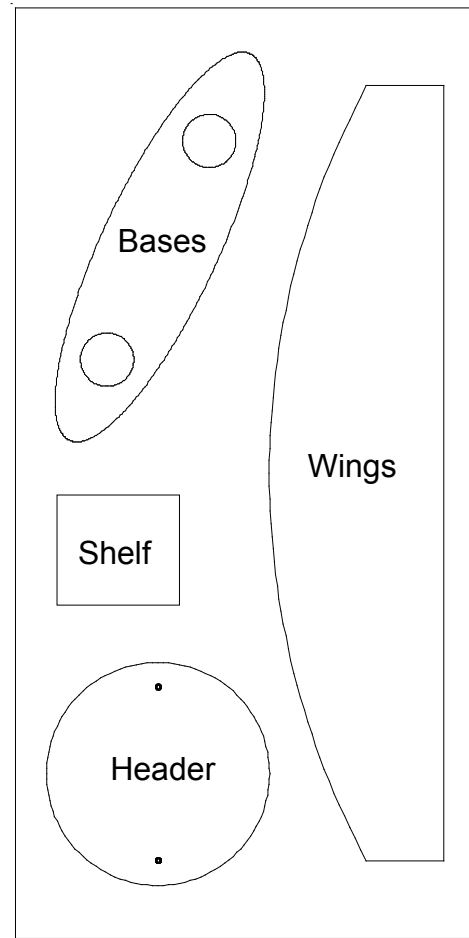

Level 1

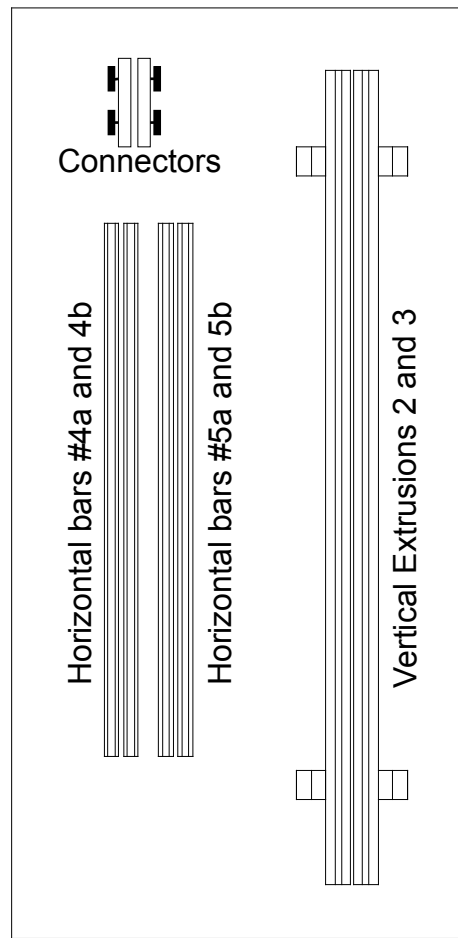

Level 2

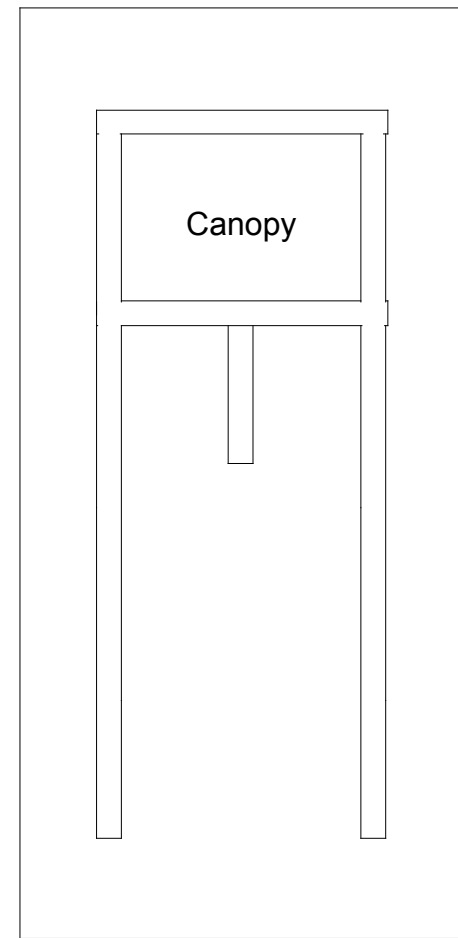

Level 3

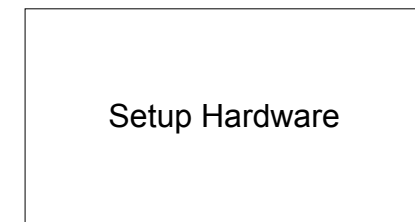
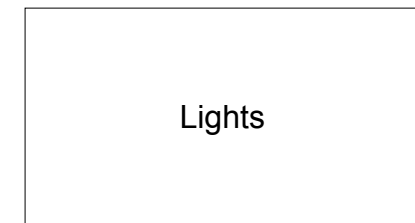

WHEN DISASSEMBLING ALUMINUM EXTRUSION, TIGHTEN ALL SETSCREWS AND LOCKS TO PREVENT LOSS DURING SHIPPING